

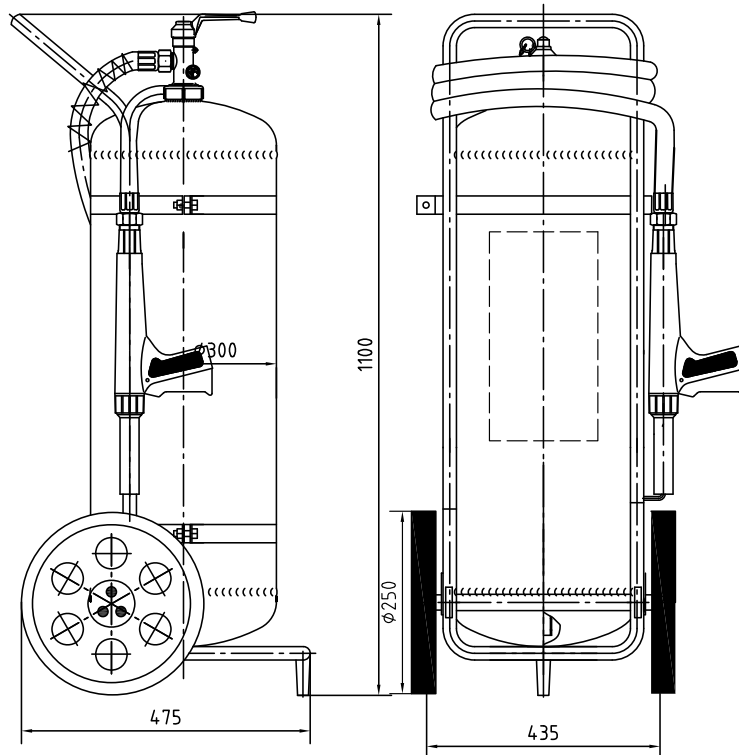

## DRY CHEMICAL POWDER AND FOAM MOBILE FIRE EXTINGUISHERS

Product Code	Component
<b>A012</b>	50Kg Dry Chemical Powder Type, Mobile Trolley Fire Extinguisher
Description	Specifications
Charge	50Kg
Fire Extinguisher Complete Full Weight	72Kg
Fire Extinguisher Complete Empty Weight	22Kg
Cylinder Empty Weight	19.9Kg
Cylinder Length (mm)	918±2
Out-cylinder diameter (mm)	300
Volume (L)	59.5
Min. Wall Thickness of Cylinder (mm)	3
Material	HP245
Discharge Time	>25 sec.
Corrosion Protection	L
Working Pressure	1400kPa
Hydrostatic Test Pressure	2100kPa
Bursting Pressure of Cylinder	>5500kPa
Safety Device	2300 ~ 2800kPa
Size / Type of Pressure Gauge Fitted	M10*1 / Diaphragm
Working Temperature	-30°C ~ +60°C
Packing Size (cm)	37 x 36 x 114.5



Cross-section



Product Code	Component
<b>A012.1</b>	50Litre 3% AFFF Type, Mobile Trolley Fire Extinguisher
Description	Specifications
Charge	50L
Fire Extinguisher Complete Full Weight	72Kg
Fire Extinguisher Complete Empty Weight	22Kg
Cylinder Empty Weight	20.6Kg
Cylinder Length (mm)	918±2
Out-cylinder diameter (mm)	300
Volume (L)	59.5
Min. Wall Thickness of Cylinder mm)	3
Material	HP245
Discharge Time	>25 sec.
Corrosion Protection	LJ766 Powder inner coating
Working Pressure	1400kPa
Hydrostatic Test Pressure	2100kPa
Bursting Pressure of Cylinder	>5500kPa
Safety Device	2300 ~ 2800kPa
Size / Type of Pressure Gauge Fitted	M10*1 / Bourdon Tube
Working Temperature	0°C ~ +60°C
Packing Size (cm)	37 x 36 x 114.5

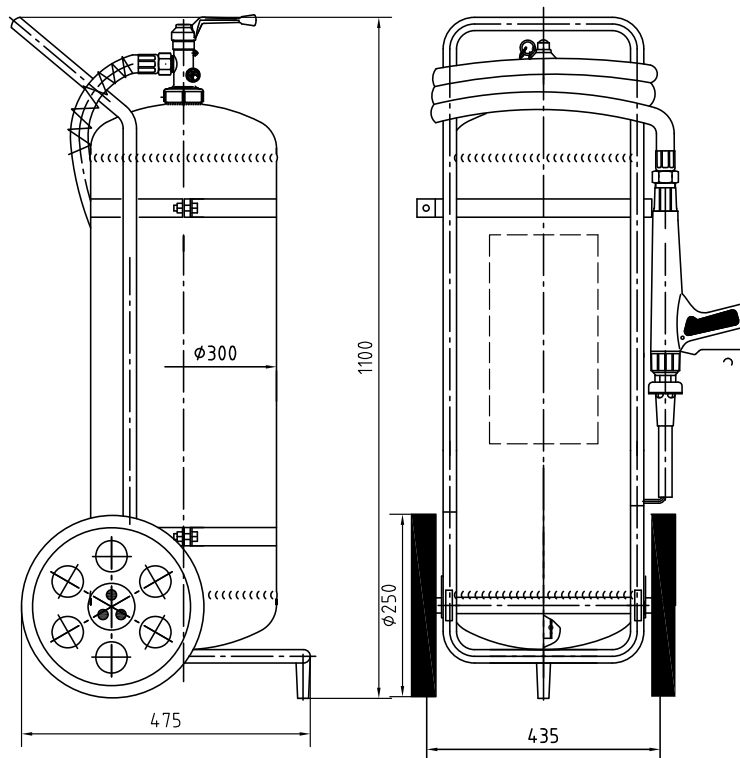

Cross-section